

X1Y2 SAFETY CAPACITORS

Safety Standard Certified Ceramic Capacitors

Feature

- Wide capacitance range from 100pF to 10000pF
- Operating Temperature: -40°C ~ 125°C
- Storage Temperature: 15°C ~ 35°C
- Fix capacitors Y2 for electromagnetic interference suppression and connection to the supply mains has high dielectric coefficient ceramic dielectric and flame retardant epoxy resin package

Applications

- Can be used for power supply noise suppression circuit in cross connection and bypass. It is a primary and secondary coupling X/Y capacitor used as AC line filter and switching power supply and AC converter

Part Number Code

<u>Y2</u>	<u>U</u>	<u>222</u>	<u>M</u>	<u>A250</u>	<u>8100</u>	<u>A</u>	<u>000</u>
Type	Material Code	Capacitance Code	Tolerance	Rated Voltage	Shap & Size Code	Package Code	Suffix Indicate Special Requirement
Y1 Y2	Dielectrics Code U: Y5U Z: Y5V P: Y5P S: SL	pF Code: 1st two digits represent significant figures 3rd digit represents multiplier (number of zeros to follow) 100= 10pF 470= 47pF 222= 2200pF	M: +/-20% K: +/-10% M: +/-20%	For AC Voltage A400: 400VAC A250: 250VAC	8100: Lead style 8 and 10mm ptich First code represent lead style code. The following 3 digits represent pitch size 100: pitch size 10mm 050: pitch size 5mm	A: Ammo Taped B: Bulk R: Tape & Reel	000: Indicating Standard If for cut leads or long leads: 000: mean standard LL 035: cut leads to 3.5mm 040: cut leads to 4mm 250: 25mm long leads

Specifications

Capacitance and Dissipation factor testing condition	25°C、1KHz、1Vrms
Dissipation Factor(tanδ)	≤2.5%
Rated Voltage	Class X1, 400 VAC, Class Y2, 250 VAC
Withstand Voltage	2500VAC
Insulation Resistance (I.R.)	IR≥10000MΩ
Temperature Characteristic	Y5P、Y5U、Y5V

Dimensions (mm) and Approval

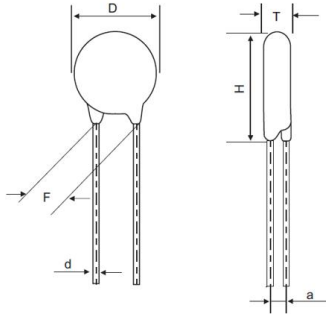

Part No.	Size (mm)				Approval				
	D Max.	T Max.	F±0.8	d±0.05	CQC	VDE	cUL (Canada)	KTL	ENEC
Y2-Y5P-101K	7.0	4.0	7.5	0.6	√	√	√	√	√
Y2-Y5P-151K	7.0	4.0	7.5	0.6	√	√	√	√	√
Y2-Y5P-221K	7.0	4.0	7.5	0.6	√	√	√	√	√
Y2-Y5P-331K	7.0	4.0	7.5	0.6	√	√	√	√	√
Y2-Y5P-471K	7.0	4.0	7.5	0.6	√	√	√	√	√
Y2-Y5P-681K	8.5	4.0	7.5	0.6	√		√	√	
Y2-Y5U-681M	7.0	4.0	7.5	0.6	√		√	√	
Y2-Y5U-102M	7.0	4.0	7.5	0.6	√	√	√	√	√
Y2-Y5U-152M	9.0	4.0	7.5	0.6	√	√	√	√	√
Y2-Y5U-222M	10.0	4.0	7.5	0.6	√	√	√	√	√
Y2-Y5U-332M	12.0	4.0	7.5	0.6	√	√	√	√	√
Y2-Y5U-472M	14.0	4.5	7.5	10.0	0.65	√	√	√	√
Y2-Y5U-103M	18.0	4.5	7.5	10.0	0.65	√	√	√	√
Y2-Y5V-152M	7.0	4.0	7.5	0.6	√	√	√	√	√
Y2-Y5V-222M	8.0	4.0	7.5	0.6	√	√	√	√	√
Y2-Y5V-332M	9.0	4.0	7.5	0.6	√	√	√	√	√
Y2-Y5V-472M	10.0	4.0	7.5	0.6	√	√	√	√	√
Y2-Y5V-103M	14.0	4.5	7.5	10.0	0.65	√	√	√	√

Lead Configuration

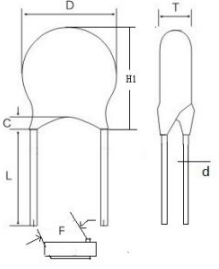
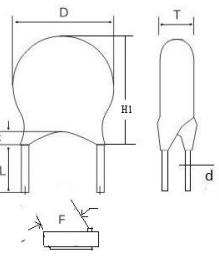
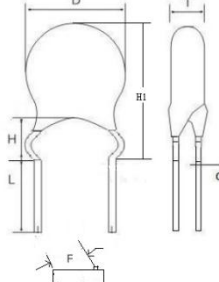
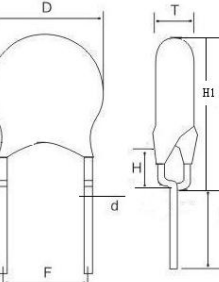
Lead Style	Drawing	Lead Length L (mm)	Coating Lead Length C (mm)	Height H (mm)
Long Straight		16.0 min	① C ≤ 2.5mm (Product diameter < 12mm) ② C ≤ 3.0mm (Product diameter ≥ 12mm)	/
Short Straight		① [2.5 ≤ L < 6.0] ± 0.5; ② [6.0 ≤ L ≤ 10] ± 1.0	① C ≤ 2.5mm (Product diameter < 12mm) ② C ≤ 3.0mm (Product diameter ≥ 12mm)	/
Outside Crimped		① [2.5 ≤ L < 6.0] ± 0.5; ② [6.0 ≤ L ≤ 10] ± 1.0	Not exceed the bend point	5.0mm Max
Vertical Crimped		① [2.5 ≤ L < 6.0] ± 0.5; ② [6.0 ≤ L ≤ 10] ± 1.0	Not exceed the bend point	4.0mm Max

Taping And Dimensions (mm)

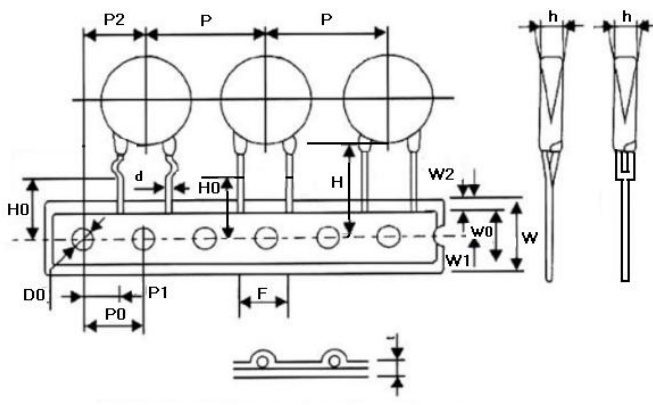
Figure	Symbol	P=7.5		P=10.0		
	Po	12.7±0.3		12.7±0.3		
	P	25.4±1.0		25.4±1.0		
	P1	8.95±0.7		7.7±0.7		
	P2	12.7±1.3		12.7±1.3		
	F	7.5±0.8		10.0±0.8		
	Δh	0±2.0		0±2.0		
	W	18.0 +1.5/-1.0		18.0 +1.5/-1.0		
	Wo	10.5 Max		10.5 Max		
	W1	9.0+0.75/-0.5		9.0+0.75/-0.5		
	W2	3.0 Max		3.0 Max		
	Do	4.0±0.2		4.0±0.2		
	H	20+1.5/-1.0		20+1.5/-1.0		
	Ho	16.5&17.0&19.0 +1.5/-1.0		16.5&17.0&19.0 +1.5/-1.0		
	L	Straight Lead	Crimped Lead		Straight Lead	Crimped Lead
		11.0 Max	9.0 Max		11.0 Max	9.0 Max
	t1	0.5±0.2		0.5±0.2		
	t2	1.7 Max		1.7 Max		

Soldering Condition Wave Soldering Graph

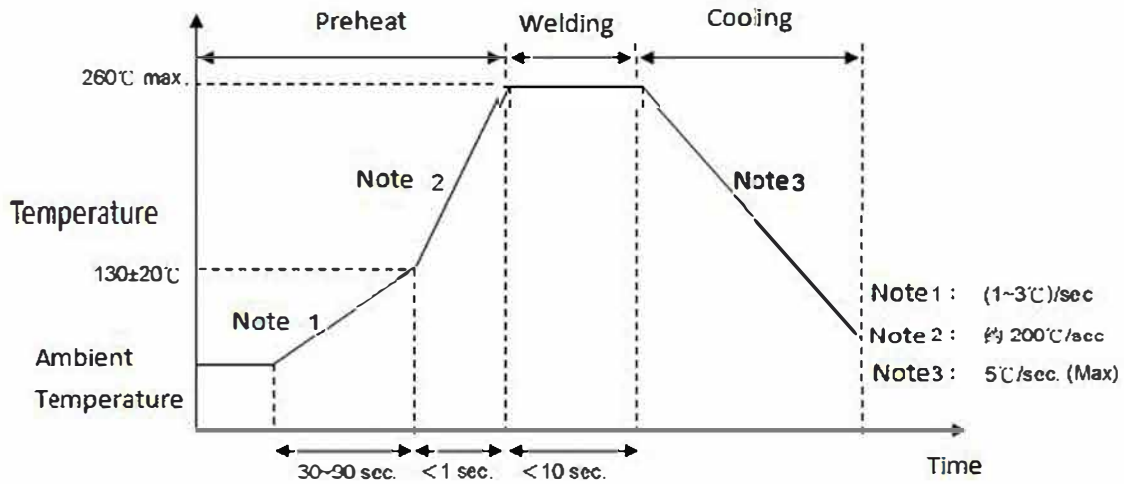

Note: Film capacitor is not suitable for reflow soldering welding, because it will cause thermal contraction and affect electrical performance.

Iron Soldering Condition

Item	Condition
Temperature of soldering copper bit	360°C (max.)
Soldering duration	3sec (max.)
Space between soldering position and coating layer	2mm (min.)